

SPARE PARTS SECTION

MANUAL DEBURRING MACHINE

Model Deburr1380

Order Code P7870

EDITION No : DEBURR1380-1

DATE OF ISSUE : 04/2023

The following section covers the spare parts diagrams and lists that were current at the time this manual was originally printed. Due to continuous improvements of the machine, changes may be made at any time without notification.

HOW TO ORDER SPARE PARTS

1. Have your machines **model number, serial number & date of manufacture** on hand, these can be found on the specification plate mounted on the machine
2. A scanned copy of your parts list/diagram with required spare part/s identified.

NOTE: SOME PARTS MAY ONLY BE AVAILABLE AS AN ASSEMBLY

3. Go to www.machineryhouse.com.au/contactus and fill out the inquiry form attaching a copy of scanned parts list.



WARNING!

Serious injury or death can result from using this machine BEFORE understanding its controls and related safety information. DO NOT operate, or allow others to operate, the machine until the information is understood.

WIRING DIAGRAM

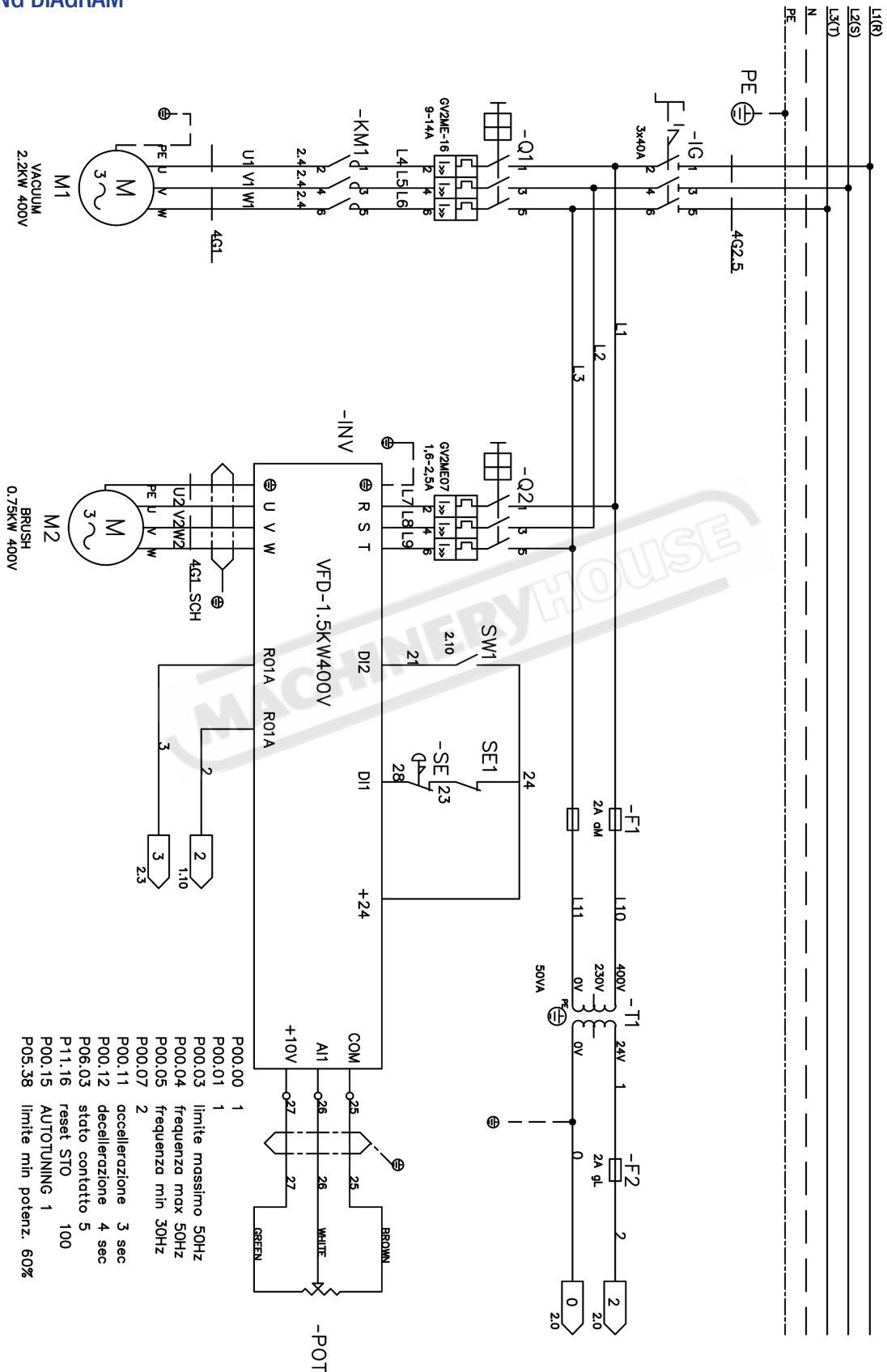

WIRING DIAGRAM

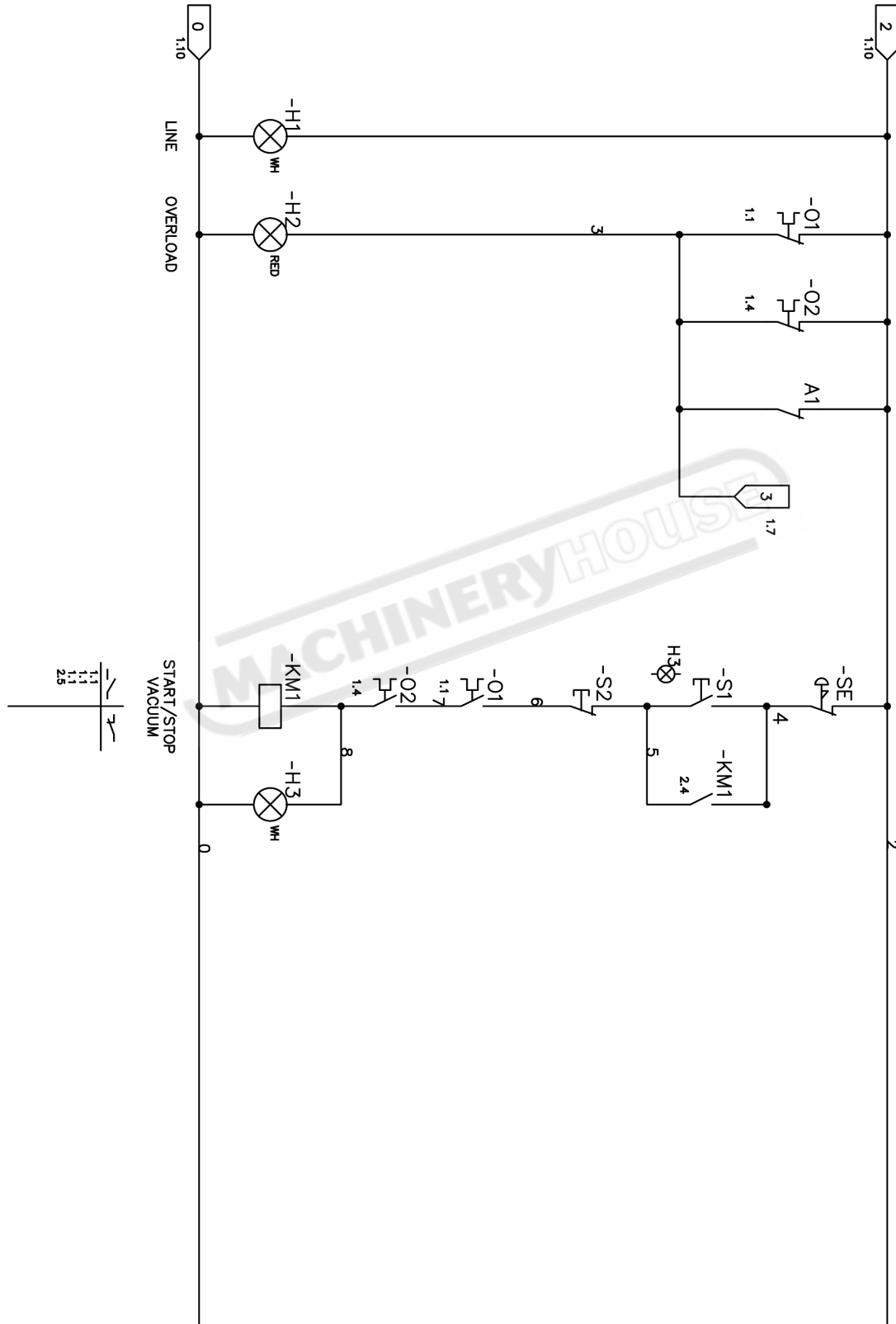

MAIN BODY PARTS

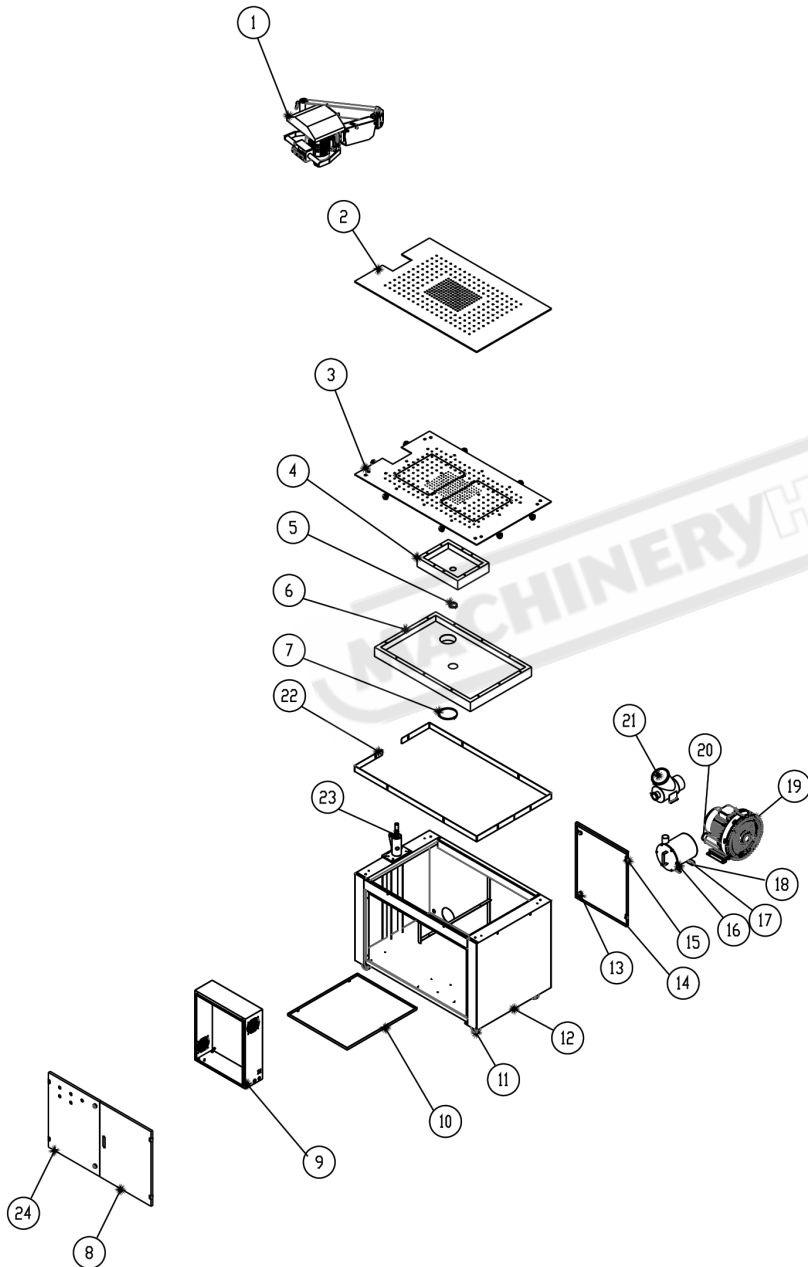

Item No.	Part No.	Description	Qty.
1	C0020004	Vertical sanding system	1
2	E0340009	Rubber table mat	1
3	D0170002	Vacuum table assembly	1
4	E0510003	Vacuum chamber	1
5	M0730001	2.5 Inch hose clamp	1
6	E0510004	Pneumatic chamber	1
7	M0730002	5 Inch hose clamp	1
8	E0020117	Electrical enclosure door	1
9	D0060006	Electric control box assembly	1
10	E0020112	Cabinet shelf	1
11	J0130002	Swivel caster	4
12	E0010023	Machine Cabinet	1
13	J0110003	Key door latch	4
14	E0020029	Rear cabinet door	1
15	J0110001	Door hinge	6
16	D0160001	Vacuum filtration	1
17	M0200612	Hex socket head cap screw	12
18	M0510060	Flat washer	12
19	J1060001	Air blower vacuum pump	1
20	M0730002	5 Inch hose clamp	1
21	E0510017	Exhaust three-way pipe	1
22	E0330079	Table Fence	2
23	E0090039ES	Cantilever axle seat	1
24	E0020028	Electrical enclosure control panel	1

HEAD SPAREPARTS DIAGRAM

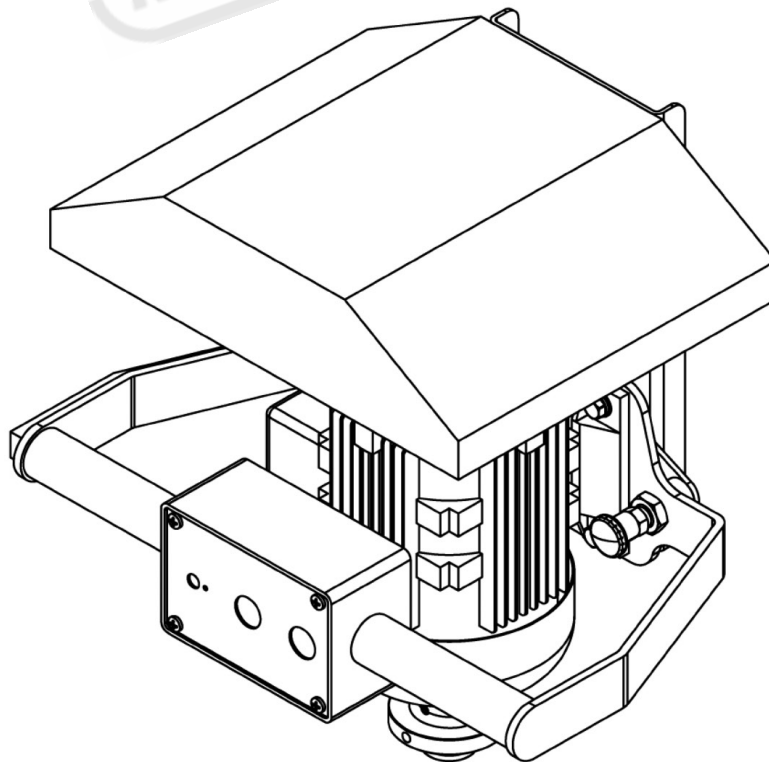
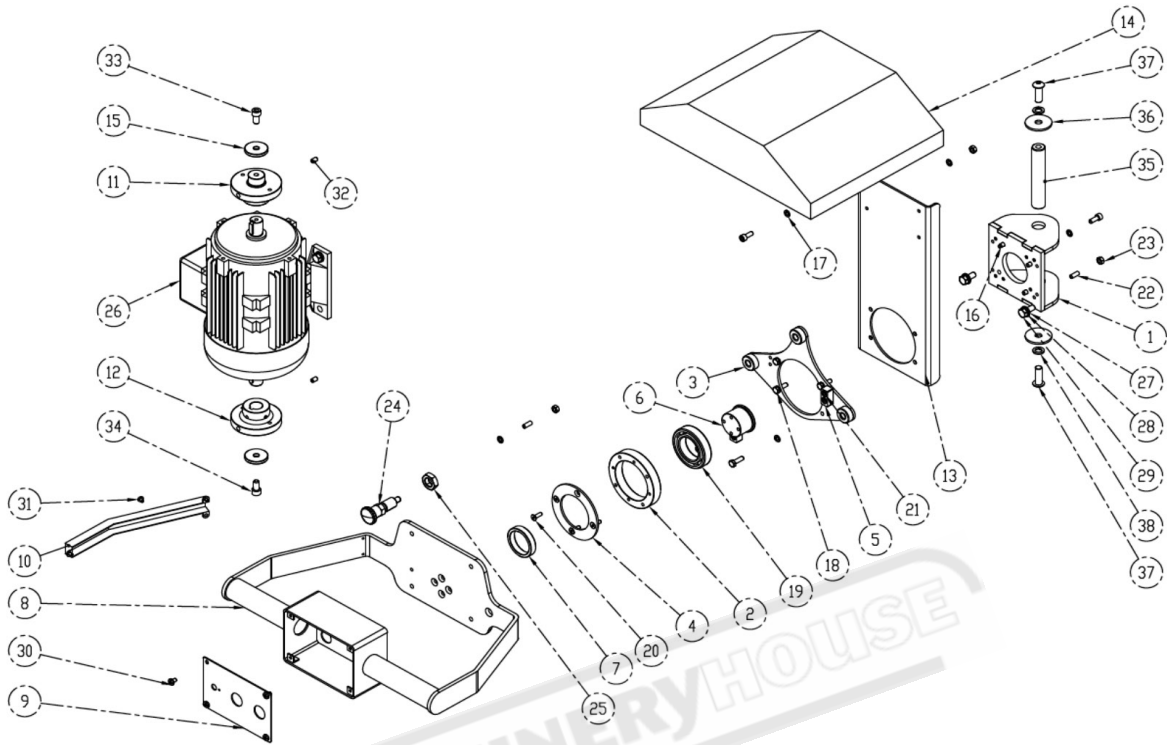

HEAD SPARE PARTS LIST

No.	FACTORY CODE	DESCRIPTION	Qty.
1	E030020	U-shaped bracket	1
2	E0090007	Handle connected base	1
3	E0330021	Abrasive head directional positioning plate	1
4	E0020031	Cover of handle connected base	1
5	E0520001	Directional locating block	2
6	E0130006	Rotational axis	1
7	E0420005	Spacer	1
8	E0320016	Control handle	1
9	E0290007	Switch panel	1
10	E0020032	Wire conduit cover	1
11	E0090008	Sanding head adapter-right thread	1
12	E0090009	Sanding head adapter-left thread	1
13	E0070007	Sanding head motor plate	1
14	E0020033	Sanding head cover	1
15	E0150003	Washer	2
16	M0200616	Hex socket screw M6*16	8
17	M0520060	Spring washer	17
18	M0400620	Hex socket head cap screw M6*20	4
19	M0060080	Deep groove ball bearings- 6008	1
20	M0200610	Hex Socket Screw M5*16	4
21	M0200610	Hex Socket Screw M6*10	4
22	M0230616	Hex socket set screw M6*16	9
23	M6	Hex nut	13
24	M0550004	Locating pin	1
25	M0500161	Hex nut	1
26	J050004	Sanding motor-1HP-4P	1
27	M0510081	Flat washer	4
28	M0520080	Spring washer	4
29	M0400820	Hex head bolt M8*20	4
30	M0240508	Cross-head screw M5*8	4
31	M0240406	Cross-head screw M4*6	3
32	M0230610	Hex socket set screw M6*10	4
33	M0200816	Hex socket screw M8*16	1
34	M0200817	Hex socket screw- left thread M8*16	1
35	E0130002	Rotational shaft	1
36	M0510102	Washer	2
37	M0211030	Hex socket screw M10*30	2
38	M0520100	Spring washer	2

CANTILEVER ASSEMBLY SPARE PARTS DIAGRAM

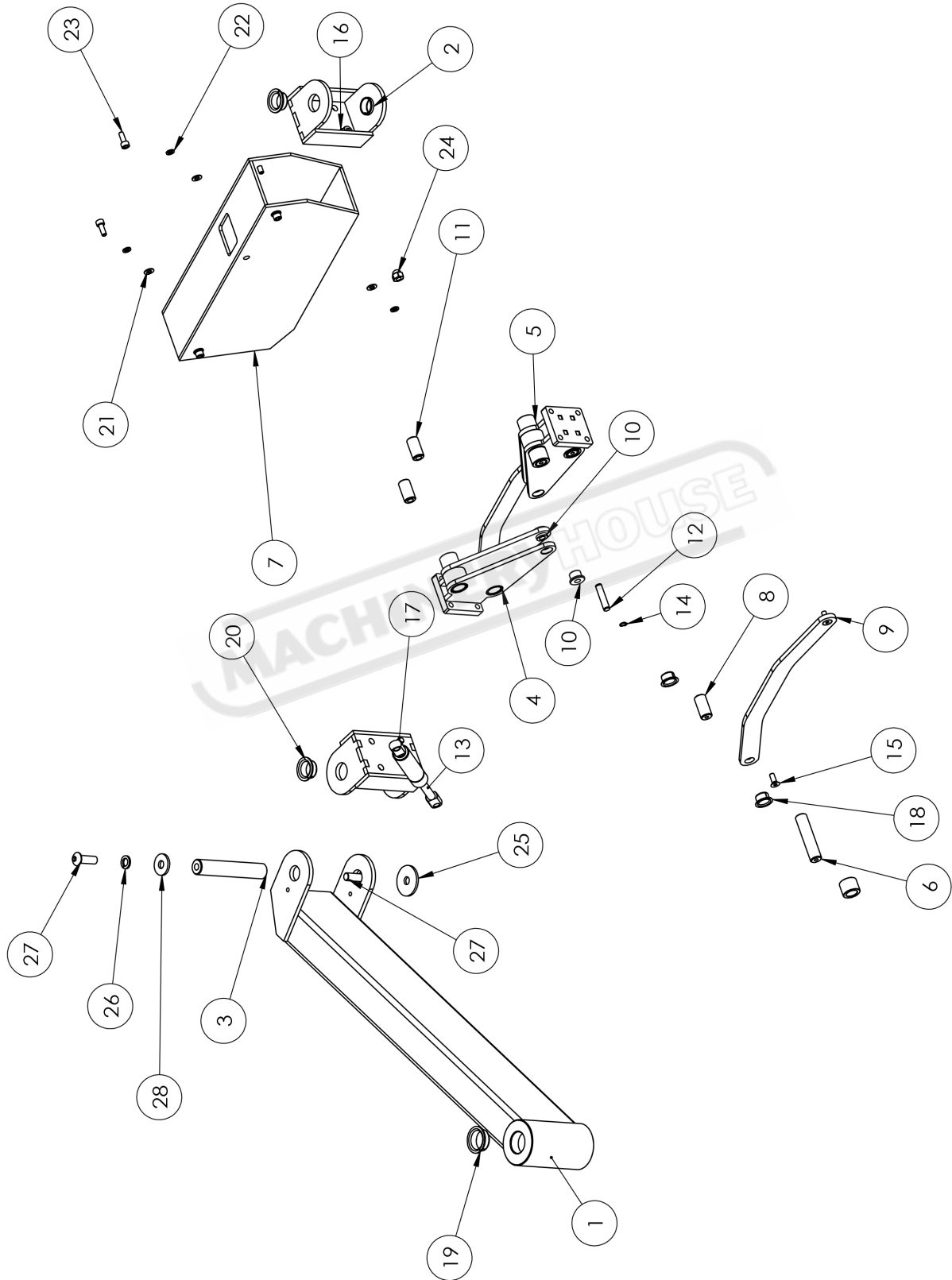

CANTILEVER ASSEMBLY SPARE PARTS LIST

No.	FACTORY CODE	DESCRIPTION	Qty.
1	E0330017	Control arm main body	1
2	E0330018	U-shaped connector	2
3	E0130002	Rotation center shaft	1
4	E0090006	Lifting brake block	2
5	E0220002	Brake shaft bushing	4
6	E0130004	Brake shaft center	2
7	E0020030	Cantilever cover	1
8	E0130005	Shaft	2
9	E0330019	Bracket	2
10	E0220003	Bushing	2
11	E0130003	Shaft bushing	2
12	E0030008	Fixed shaft	1
13	J0990001	Nitrogen gas spring rod	1
14	M0080080	CS008	2
15	M0220616	Hex socket screw M6*16	4
16	M0520080	Spring washer	2
17	M0200816	Hex socket screw M8*12	2
18	M0100003	Self-lubricating bushing	8
19	M0510060	Flat washer	6
20	M0520060	Spring washer	6
21	M0200616	Hex socket screw M6*16	5
22	M0490080	M8 dome nut	1
23	M0100004	Self-lubricating bearing	2
24	M0100005	Self-lubricating bushing	4
25	M0510103	Flat washer	1
26	M0520100	Spring washer	2
27	M0211030	Hex socket screw M10*30	2
28	M0510102	Flat washer	1

FILTER SPARE PARTS

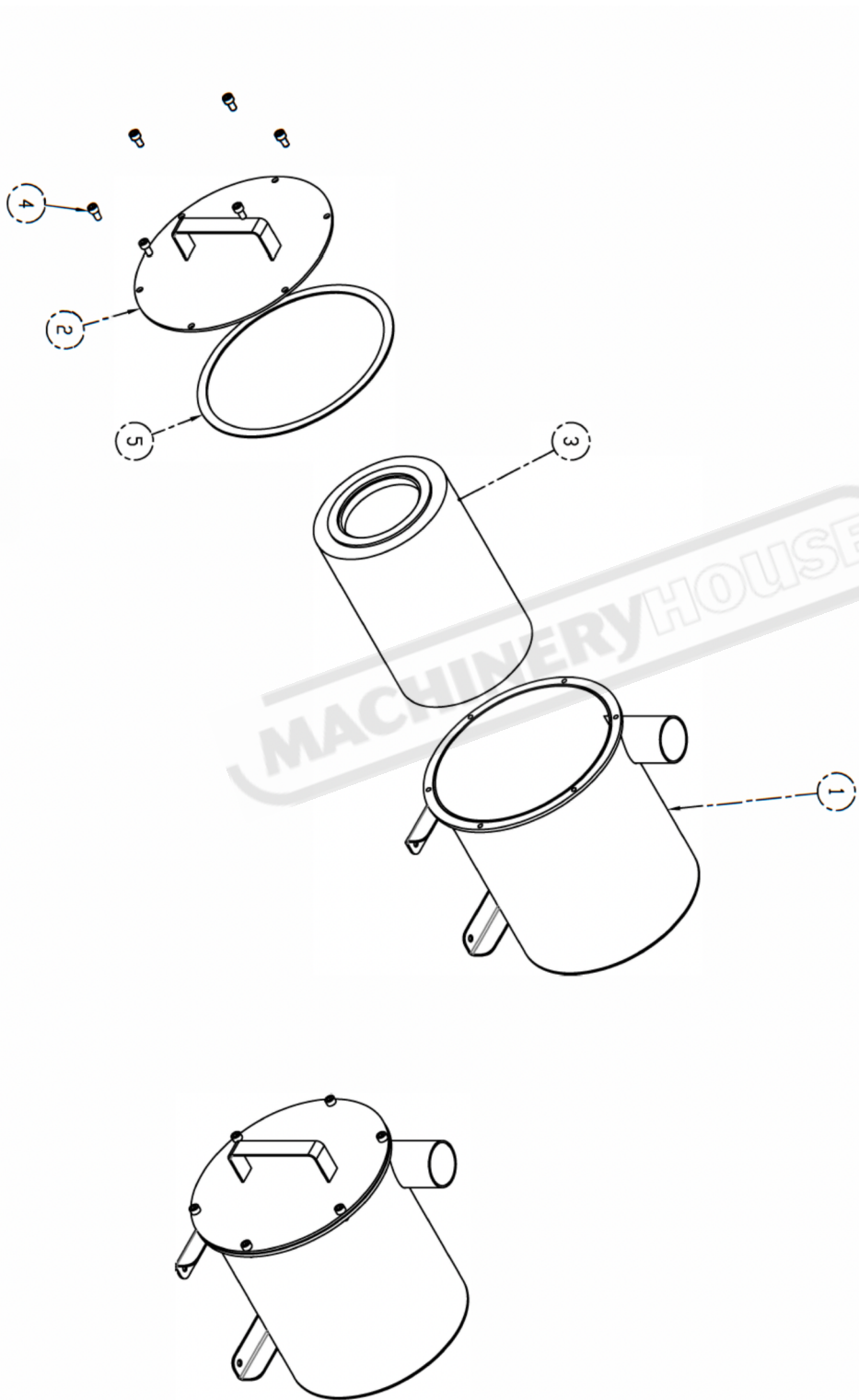

NO.	Part no.	Description	Qty
1	E0500001	Filter tank	1
2	E0500002	Filter tank cover	1
3	J1040001	Filter	1
4	M0200612	Hex socket screw M6*12	6
5	J1050001	Sealing foam padding	1